



VIKING WINDOW LIFT AND SLIDE PATIO DOOR

Viking Window AS is an Estonian company which started the production of timber windows and exterior doors in 1997. Today the company has become one of the leading manufacturers of outward opening timber and aluminum clad windows. Its products are highly valued on the international market. In addition to the United Kingdom and Ireland, Viking Window products are sold to Sweden, Norway, Denmark, Iceland, France and Japan. Viking Windows pride themselves on high quality products, a client-friendly service, and most importantly fast and efficient delivery. All our products are manufactured following exact specifications from each client using environmentally friendly materials.



Since 2000, Viking Window AS has been applying a quality management system which complies with the ISO 9001 standard, and since 2005 the environmental management system has complied with the ISO 14001 standard.



Since 2007, we have the FSC Chain of Custody certificate which proves that we use timber from responsibly managed forests. Our production methods also comply with the British standard, BS 644.



In 2009 compliance to Norwegian Door and Window standards was certified.

Lift and slide patio door is best for locations as balconies, terraces and other places where there is not enough room for traditional outward or inward opening solutions. Lift and slide patio door is ideal for rooms where is a need for large glazed areas.

Viking Window sliding patio doors are equipped with high quality and modern GU-934-H hinges system which has load bearing capability 300 kg. Active door part is located on inner side of door ensuring functionality for winter times - ice and snow does not damage rails. The espagnolette and strong handle enable convenient operating and possibility to close door in ventilation position.

Sliding patio door is available both as wooden and aluminum clad door. Wooden sliding door is suitable for houses with traditional look. Aluminum clad sliding door where external side of door is covered with aluminum profiles is best suitable for modern houses.

Traditional double glazing ($U_g = 1,1 \text{ W/m}^2\text{K}$) or energy efficient triple glazing ($U_g = 0,6 \text{ W/m}^2\text{K}$) can be used. Finishing according RAL, NCS (paint) or Vikings (lacquer) tone catalog by customer's choice preference.



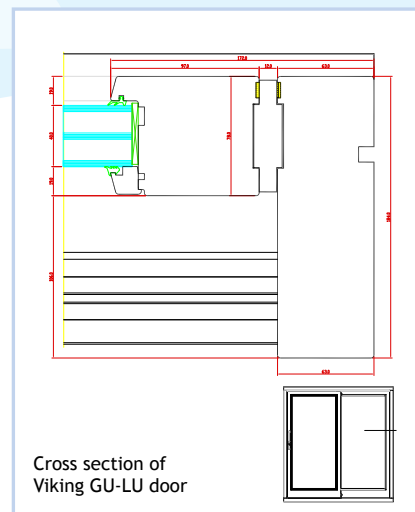
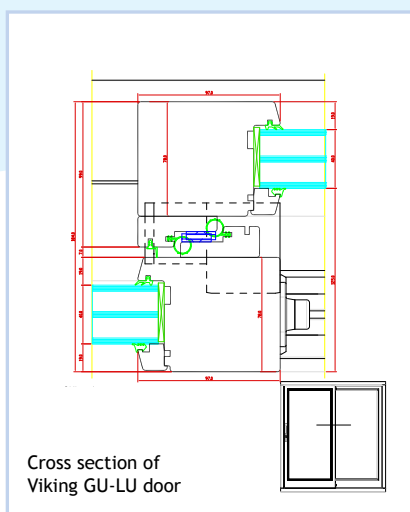
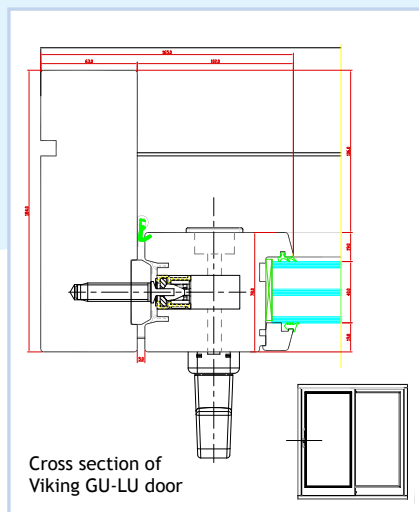

Technical properties of lift and slide door

- Thermal transmittance:
 - $U_w = 1,4 \text{ W/m}^2\text{K}$ with double glazing;
 - $U_w = 1,0 \text{ W/m}^2\text{K}$ with triple glazing.
- Cross sections: frame 63 x 184 mm; leaf 97 x 78 mm; transom/mullion 85 x 78 mm; glazing bar 63 x 78 mm.
- Pine wood with quality class A1-A3; threshold GU-934-H (height 67 mm).
- Frame dimensions: W x H min 1,44 x 1,99 m; max 5,0 x 2,6 m.
- Weight of opening door leaf up to 300 kg.
- Wooden profiles treated with water based preservative.
- Glass and infills:
 - double glazing (26 mm; $U_g = 1,1 \text{ W/m}^2\text{K}$); insulated 26 mm veneer or MDF panels; insulated 40 mm timber or MDF profiled panel;
 - triple glazing (40 mm; $U_g = 0,6 \text{ W/m}^2\text{K}$); insulated 26 mm veneer or MDF panels; insulated 40 mm timber or MDF profiled panel.
- Hardware: GU-934-H hinges and locking system.

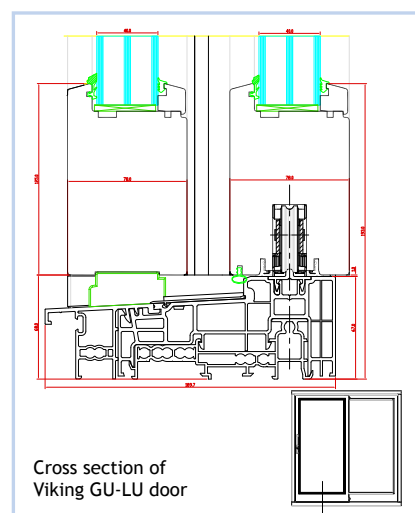
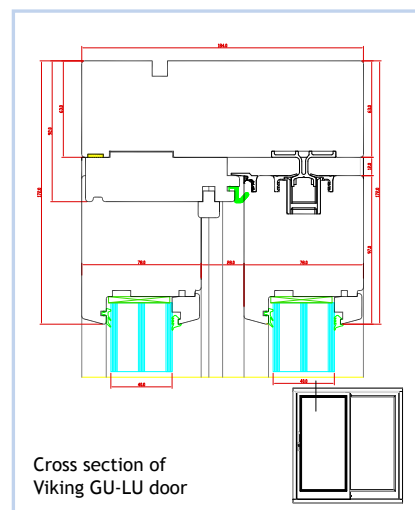

Warranty

All products come with a five year warranty.

www.vikingwindow.eu

HEAD OFFICE AND PRODUCTION
Mäo 72751 Järva County Estonia
Phone +372 384 8900
Fax +372 385 3027
e-mail: viking@viking.ee
www.vikingwindow.eu